

HIGH-PRECISION, HIGH-PRODUCTIVITY
LARGE SIZE MULTI-TASKING TURNING CENTER

SMX 5100

SMX 5100L/LB/LS/LSB/XL/XLB



SMX 5100

SMX 5100 series is large capacity, (up to 4 metre maximum turning length), multi-tasking turning centers equipped with high power/torque spindles and wide machining areas. The machines are ideal for the complex mill-turn machining of long and large-diameter workpieces typically found in the oil and gas, aerospace, large automotive sectors. SMX 5100 feature thermal compensation systems that minimize thermal deformation and deliver consistently high precision.

The machines' ergonomic design, that has taken into account operator convenience and efficient maintenance, provides an optimal solution that meets every customer's requirements.

CONTENTS

Product Overview

Basic Information

- 04** Basic Structure
- 05** Cooling Concept Maintains High Accuracy Over Long Machining Runs
- 06** Machining Area
- 07** Cutting Performance
- 08** Spindle
- 09** Tailstock
- 10** Automatic Tool Changer
- 11** Additional Tool Magazine
- 12** Ergonomic Design

Detailed Information

- 13** CUFOS
- 17** SINUMERIK ONE
- 18** Standard / Optional Specifications
- 19** Peripheral Equipment
- 20** Power | Torque
- 21** External Dimensions
- 23** Working Range
- 26** Machine Specifications

Customer Support Service

- 27** Customer Support and Services
- 27** Global Network



**HIGHER PRODUCTIVITY
THROUGH
POWERFUL MULTI-TASKING
FUNCTIONS**



- Complex machining capabilities of left spindle, right spindle, B-axis, milling spindle
- Built-in spindle/high-torque Big bore spindle can be selected according to customer's machining conditions and needs
- High-rigidity machine construction using structural analysis design
- Maximized Y-axis machining area through orthogonal design structure

**ENHANCED PRECISION
THROUGH HIGH ACCURACY
CONTROL FUNCTIONS**

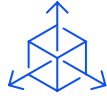

- Minimized thermal deformation of the spindle and feed axis using oil cooler
- Adoption of roller LM guideways with highrigidity and high precision
- Equipped with 0.0001° B-axis and C-axis accuracy control function

**EASY AND CONVENIENT
OPERATION THROUGH AN
ERGONOMIC DESIGN**



- CUFOS CNC with CPS(Collision protection system), Tool management and additional customized functions
- Wide door and easy spindle accessibility for convenient workpiece loading/ unloading
- Side-to-side movable swiveling operation panel with adjustable height
- Convenient ATC operation panel



BASIC STRUCTURE

Optimized orthogonal structure secures a wide working area, easy operation and stability for high precision machining.

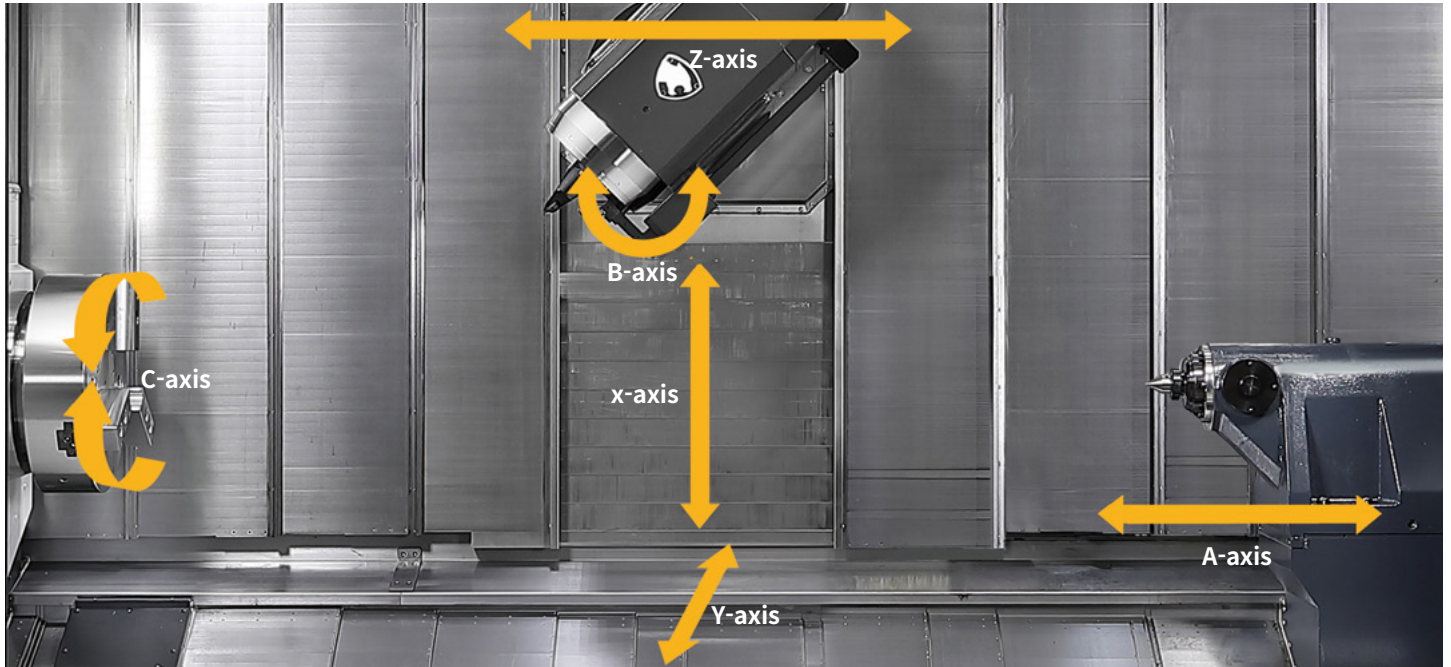

Robust design

FEM (Finite Element Method) analysis results in superior machine stability. All guideways are sealed with protective covers. This prevents hot chips and coolant from contacting the guideways, thereby maintaining long-term accuracy.

Feed axis

Best-in-class X-axis travel (910mm) and Y-axis travel (520mm), in addition to the machine's orthogonal design and linear drives deliver speed, precision and flexibility.

Travel

	SMX 5100L/LB	SMX 5100LS/LSB	SMX 5100XL/XLB
X-axis	910(-30/+880) mm	35(-1.2/+34.6) inch	
Y-axis	520(±260) mm	20.5(±10.2) inch	
Z-axis	3215 mm (126.6 inch)		4215 mm 165.9 inch)
A-axis*	3100 mm (122.0 inch)		4100 mm (161.4 inch)
B-axis	240(±120)°mm	20.5(±10.2) inch	

* Tailstock/Right Spindle travel

Rapid traverse rate

	SMX 5100L/LB	SMX 5100LS/LSB	SMX 5100XL/XLB
X-axis		40 m/min (1574.8 ipm)	
Y-axis		40 m/min (1574.8 ipm)	
Z-axis	40 m/min (1574.8 ipm)		30 m/min (1181.1 ipm)
A-axis*	-	14 m/min (551.2 ipm)	-
B-axis		30 r/min (1181.1 ipm)	

High precision roller-type LM guideways

High precision roller type LM guideways minimize noncutting time through high rapid rates.

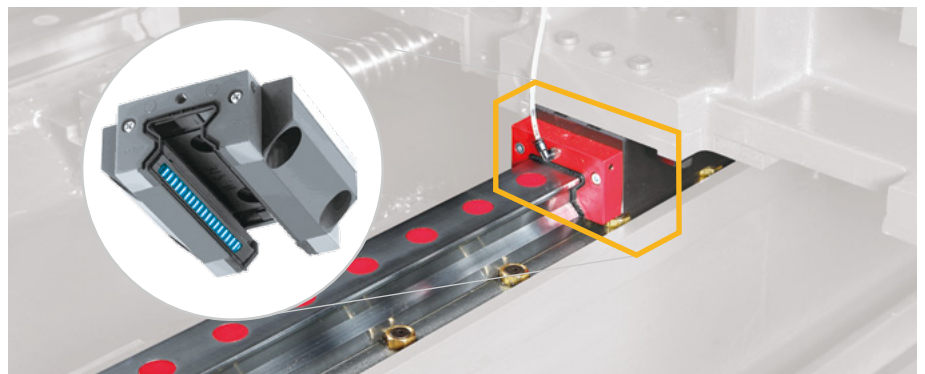

COOLING CONCEPT MAINTAINS HIGH ACCURACY OVER LONG MACHINING RUNS

Design and structure reduces thermal error and ensures superior accuracy over long machining runs.

Minimization of thermal deformation by oil cooling

Spindle and ball screw core cooling system minimizes thermal deformation during long machining processes and enhances high accuracy performance.

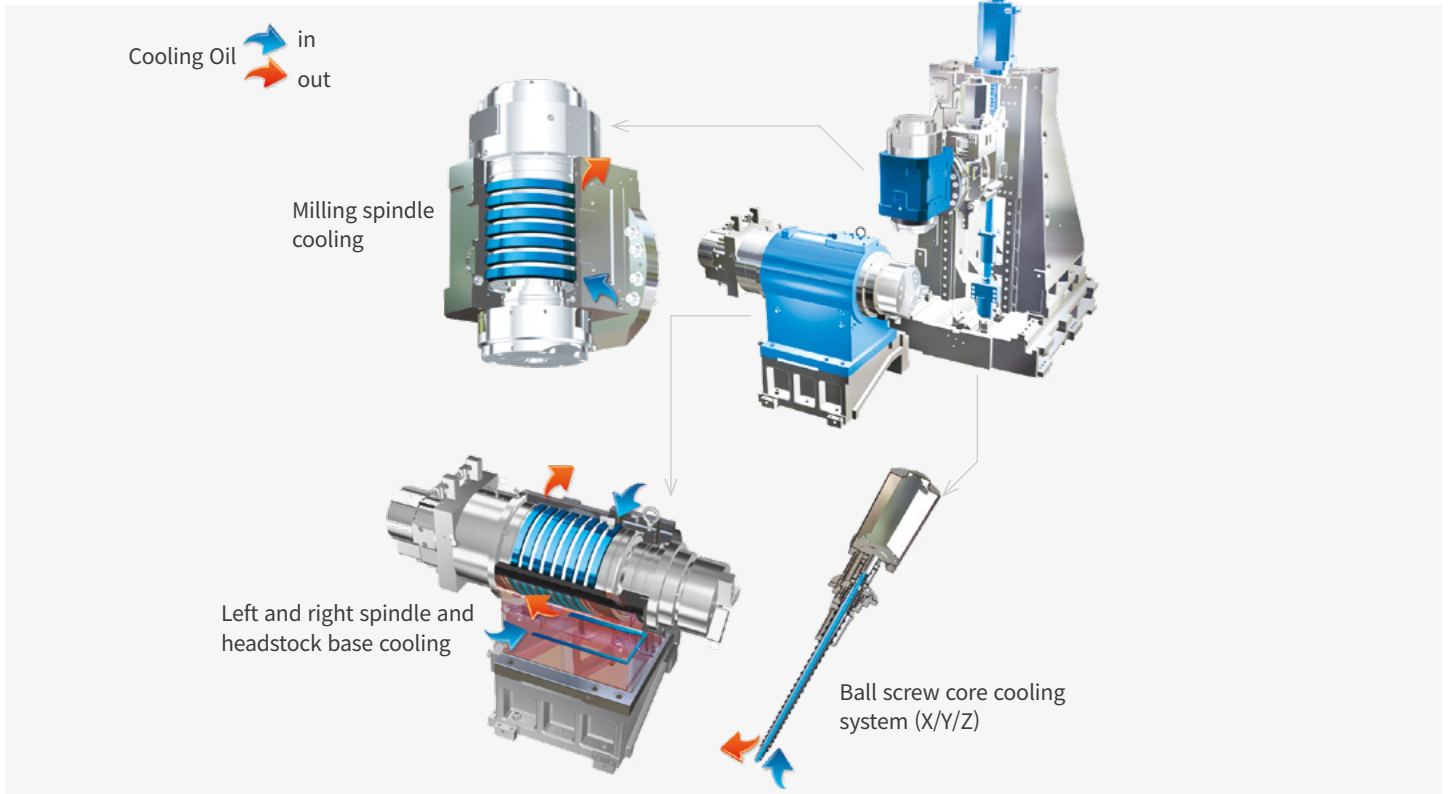

Roundness and surface roughness

By systematically testing individual machine elements and analysing the results, the SMX 5100 series is able to deliver precision and reliability, and high levels of customer satisfaction.



Turning (O.D. machining)

Roundness
5 μm

Material	Aluminium
Tool	Endmill Ø10 mm (TAEGUTEC)
Spindle speed	12000 r/min
Feedrate	300 mm/min



Milling (X-Y plane)

Roundness
0.39 μm

Material	Aluminium
Tool	OD tool (SANDVIK)
Spindle speed	1000 r/min
Feedrate	0.1 mm/rev

** This test is performed in a DN Solutions's test environment.*

Roundness
1.25 μm

Material	Aluminium
Tool	OD tool (SANDVIK)
Spindle speed	1500 r/min
Feedrate	0.1 mm/rev

MACHINING AREA

Orthogonal structure increases machining capacity and the extended turning diameter enables the machining of large size workpieces.

Maximized Y-axis machining area through orthogonal structure design

Maximized Y-axis machining area due to the orthogonal design structure enables the machining of a wide range of workpieces.

Y-axis machining area

520 mm
(20.5 inch)

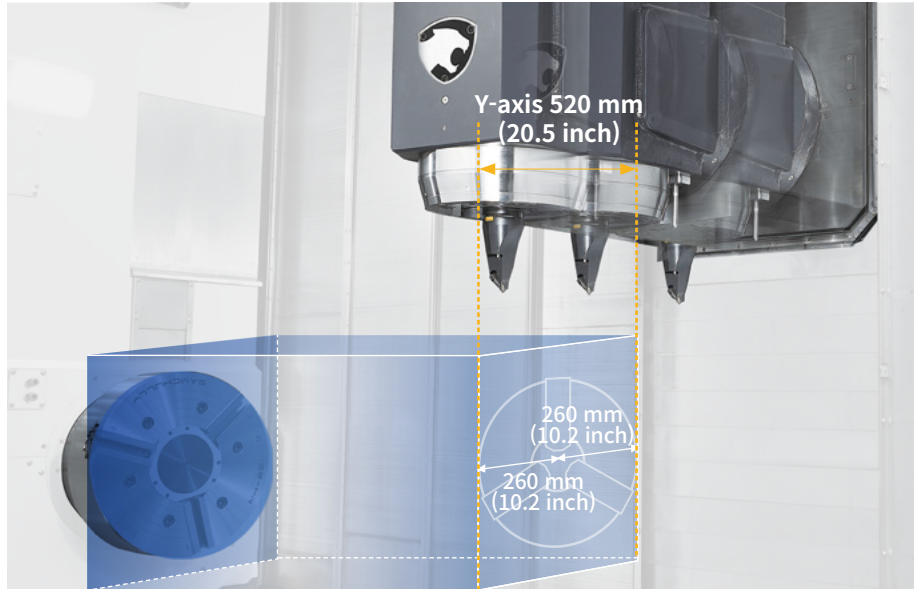

Gear skiving solutions

We can help manufacturers dramatically improve their productivity with gear machining solutions such as power skiving, invo-milling and hobbing: all of which enable highprecision external / internal gear machining in a single setup.

** Please contact DN Solutions for further information.*

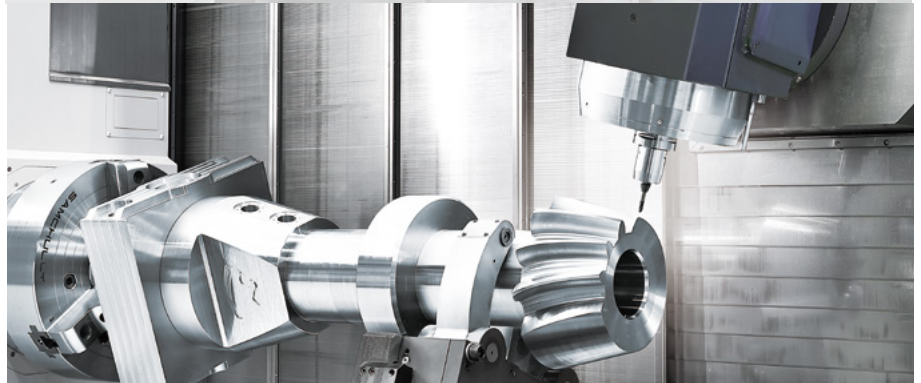

Extended machining area

The extended machining area allows for the machining of large diameter workpieces up to 4 metres in length.

Max. machining diameter

830 mm
(32.7 inch)

Max. machining length

SMX 5100L/LB/LS/LSB

3050 mm
(120.1 inch)

SMX 5100XL/XLB

4070 mm
(160.2 inch)

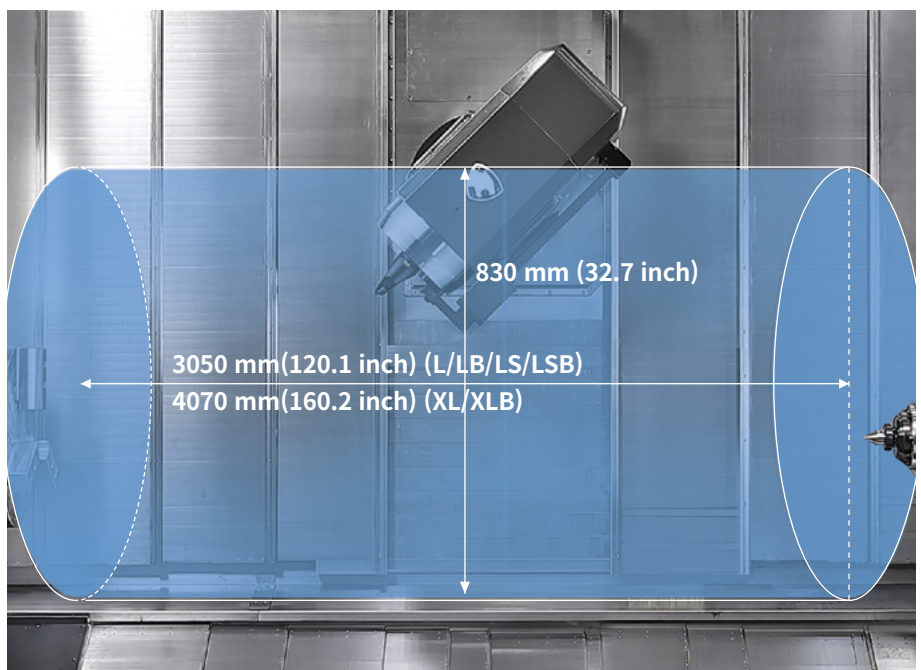

CUTTING PERFORMANCE

Powerful and fast machining capability across turning, milling, drilling, tapping and other multi-tasking operations ensures higher productivity and efficiency.

Powerful machining

O.D. cutting

Spindle speed r/min	Cutting speed m/min (ipm)	Feedrate mm/rev	Radial cutting depth mm (inch)	Material removal rate cm ³ /min (inch ³ /min)
253	210 (8267.7)	0.55 (0.0)	8.5 (0.3)	1405 (85.7)

U-drill (milling)

Tool mm (inch)	Spindle speed r/min	Feedrate mm/min (ipm)	Material removal rate cm ³ /min (inch ³ /min)
Ø80 (Ø3.1)	796	200 (7.9)	600 (36.6)

Face milling

Tool mm (inch)	Spindle speed r/min	Radial cutting depth mm (inch)	Feedrate mm/min (ipm)	Material removal rate cm ³ /min (inch ³ /min)
Ø100 (Ø3.9)	637	7 (0.3)	1114 (43.9)	602 (36.7)

End milling

Tool mm (inch)	Spindle speed r/min	Radial cutting depth mm (inch)	Feedrate mm/min (ipm)	Material removal rate cm ³ /min (inch ³ /min)
Ø32 (Ø1.3)	597	32 (1.3)	350 (13.8)	358 (21.8)

Tapping

Tool mm (inch)	Spindle speed r/min	Feedrate mm/min (ipm)
M36 x P4.0 (M1.4 x P0.2)	221	4.0 (0.2)

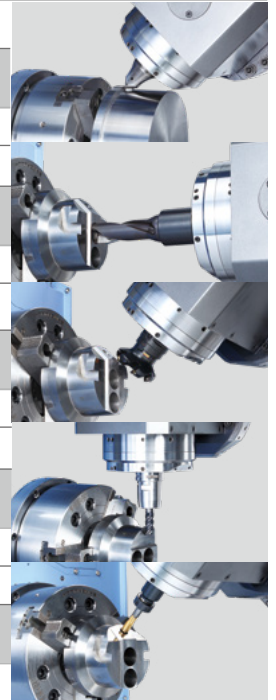

* The results (above) are provided as examples. Differences in cutting and environmental conditions will deliver different results.

Higher productivity by multi-tasking performance

Faster machining times compared to working with many conventional machines provides superior productivity and machining capability.

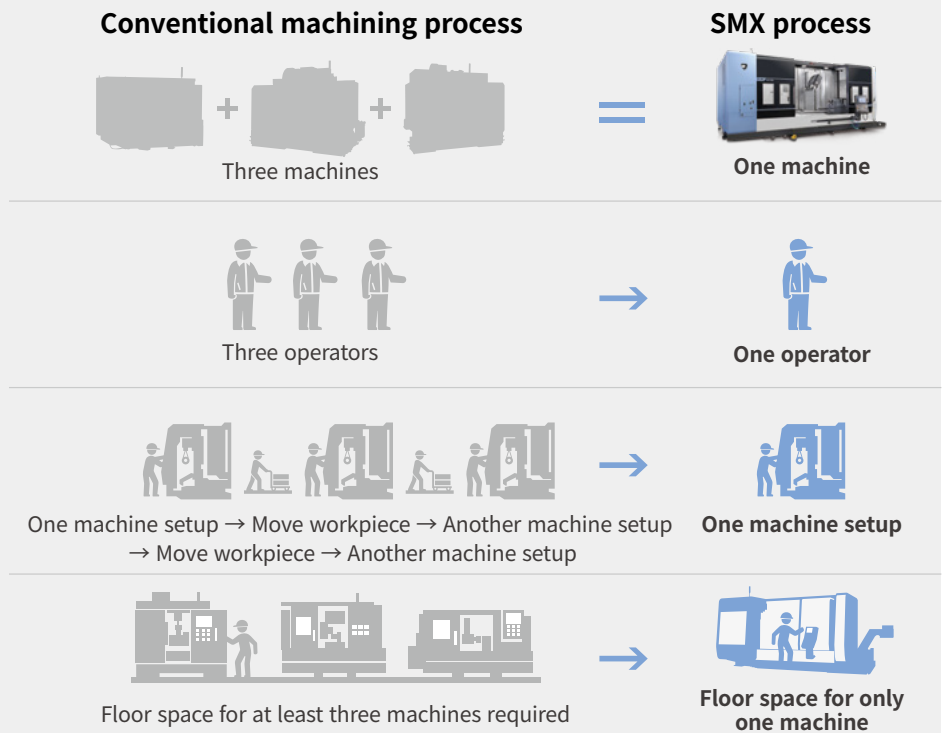

SPINDLE

Built-in spindle or high-torque big-bore spindle can be selected depending on machining conditions: for example - a) high-precision 5-axis contouring and b) heavy-duty machining of difficult-to-machine materials.

Milling spindle

10000 r/min

Milling spindle power

37 kW
(49.6 hp)

Tool shank of milling spindle

Coromant Capto® C8

{HSK-T100 OPTION}

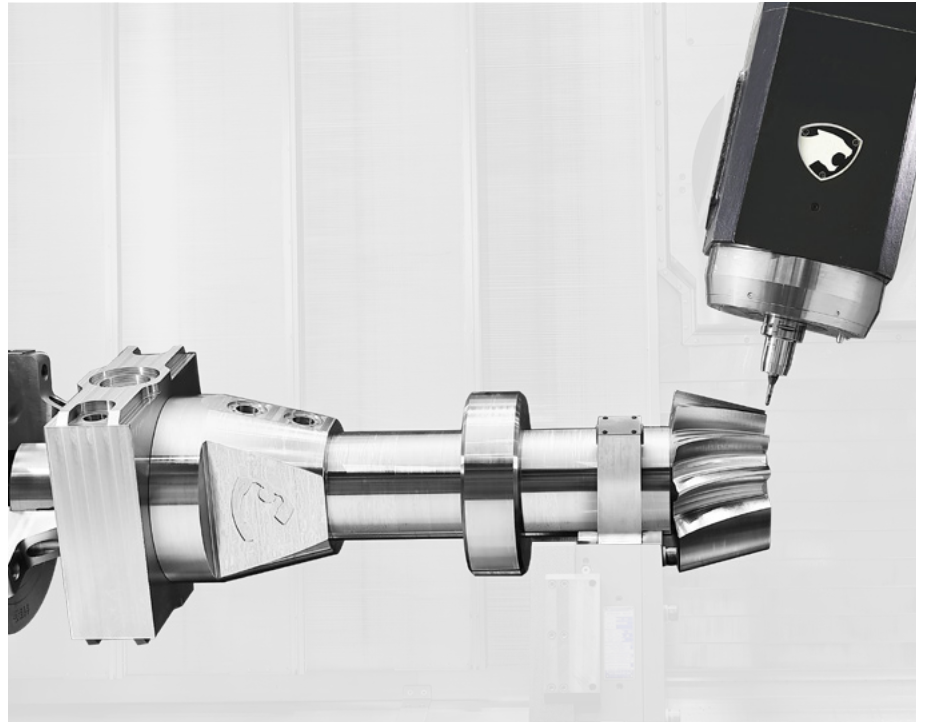

Perfect combination of rotating spindles

Both left and right spindles are capable of high-accuracy C-axis operation and, with the milling spindle, can perform various machining functions like turning, milling and synchronized cutting in a single set up.

5-axis
Contouring

Aerospace,
Precision
machinery

Heavy-duty
cutting
difficult-
tomachine
materials

Oil/energy,
General
machinery

Built-in spindle

SMX 5100L/LS/XL
15" chuck, 18" chuck OPTION

High-torque big-bore spindle

SMX 5100LB/LSB/XLB
21" chuck, 24" chuck OPTION

Model	Spindle	Standard Chuck inch	Spindle speed r/min	Power kW (Hp)	Torque N·m (ft-lbs)	Condition
SMX 5100L/LS/XL	Left spindle	15	2400	37/30 (49.6/40.2)	1643 (1212.5)	30min/cont.
SMX 5100LB/LSB/XLB		21	1500		4200 (3099.6)	
SMX 5100LS	Right spindle	15	2400		1643 (1212.5)	
SMX 5100LSB		21	1500		4200 (3099.6)	

Model	Spindle	Standard Chuck inch	Spindle speed r/min	Power kW (Hp)	Torque N·m (ft-lbs)	Condition
SMX 5100L/LS/XL	Milling spindle	CAPTO C8	10000	37/30/25 (49.6/40.2/33.5)	302 (222.9)	2.5min/ 30min/cont.
SMX 5100LB/LSB/XLB						

Machining all angles (C & B-axis)

Machining is mainly done with the Left and Milling spindles. The C-axis of the left spindle and B-axis of the milling spindle, with Y-axis control, create a multi-tasking turning center that can drill, tap and end mill in any angle as well as machine contours to high precision. (5-axis simultaneous machining is an option).

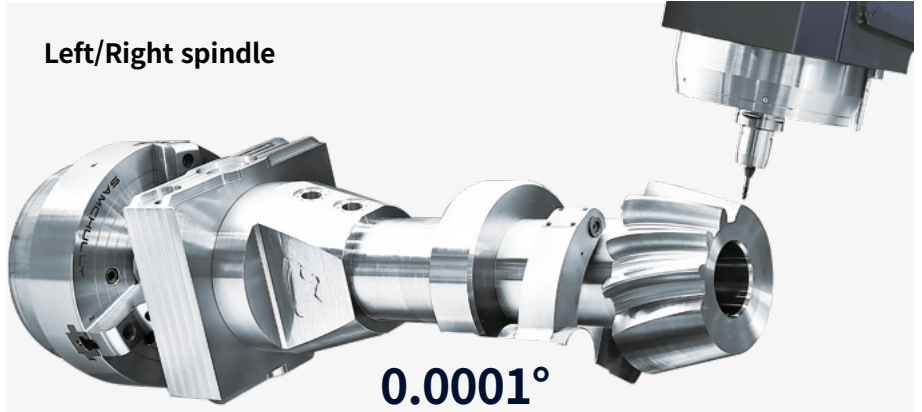
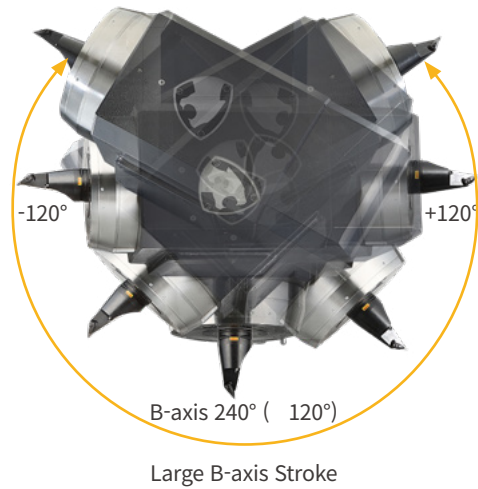

C-axis positioning control

To enhance C-axis positional accuracy of the left spindle, a position compensation sensor has been adopted. Left and Right spindles can have C-axis positioning control over every 0.0001° in 360°.

B-axis positioning control precise continuous indexing

B-axis indexing movement every 0.0001° in ±120° enables not just horizontal front face machining but also complex angular machining too.



Swivel and indexing of the B-axis is driven by a servo motor and a roller gear cam, ensuring sufficient rigidity for powerful cutting as well as for high-precision positional control.

Emergency braking function

In case of non-scheduled stoppages caused by power outages etc., the braking function protects operators and workpieces.

TAILSTOCK

Easier and faster set-up of the tailstock using M-code program can be achieved.

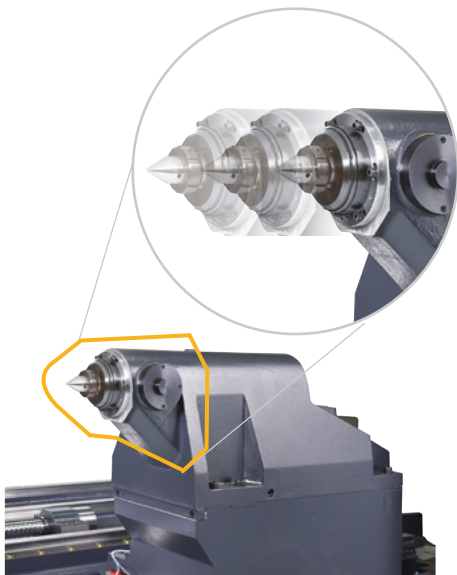

Servo driven tailstock

The operator inputs the correct M-code information in the control and the tailstock moves to its proper position automatically through the linear motion control of the servo motor and ball screw. This delivers improved efficiency by reducing set-up times and non-cutting times.

Model	Tail stock travel mm (inch)	Max. quill thrust force kN	Tail stock center
SMX 5100L	3100 (122.0)	15	MT#5 (빌트인 타입 Dead Center)
SMX 5100LB	3100 (122.0)	20	
SMX 5100XL/XLB	4100 (161.4)	24	MT#6 (빌트인타입 Dead Center)

AUTOMATIC TOOL CHANGER

Servo ATC and servo tool magazine ensuring fast and reliable tool indexing.

Tool storage

40 {80/120 **OPTION**} tools

Max. tool length (from gauge line)

600 mm
(23.6 inch)

Max. tool weight

30 kg
(66.1 lb)

Max. tool moment

29.4 N·m
(21.7 ft-lbs)

Max. tool diameter
(continuous)

Ø135 mm
(5.3 inch)

Max. tool diameter
(adjacent pots are empty)

Ø260 mm
(10.2 inch)

Enlarged touch screen panel is available as an option

10.4 inch

Servo driven ATC & Tool magazine

The tool magazine capacity can be increased to 120 tools. Tools are selected by the fixed address method that helps reduce changeover times.

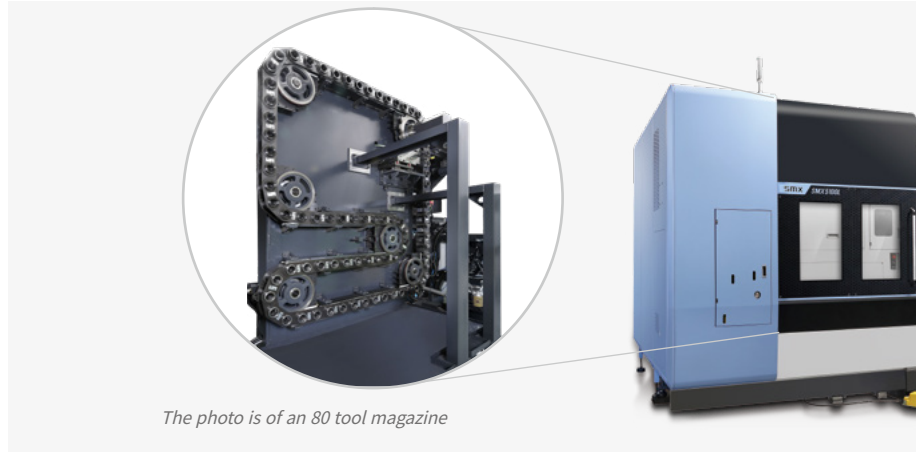

The photo is of an 80 tool magazine

ATC operation panel

The status of the ATC and the tool magazine unit can be seen, reviewed and monitored via the touchscreen. The touchscreen is used to operate the ATC, the tool magazine and the tool pot carrier.

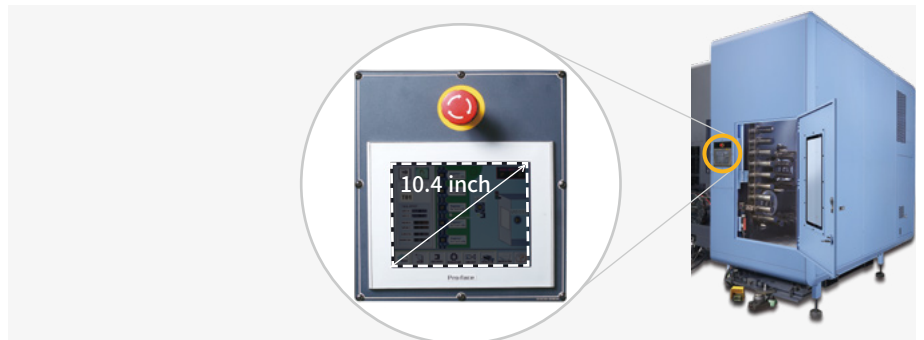

ATC magazine information display

The operational status of the ATC magazine, which is difficult to check from outside, can be seen at a glance on 10.4" big screen.



Convenient touchscreen operation

Available buttons are activated according to current and next step operations. In this way complex manual operations are undertaken logically and easily.



Tool magazine monitoring

Tool magazine status can be monitored in real time by a CCTV installed inside the magazine.

ADDITIONAL TOOL MAGAZINE

Optional LBB (Long boring bar) and long tool magazines can enable fast and efficient ID turning and milling of long pipes, tubes and shafts.

Automatic LBB changer package & long tool magazine OPTION

SMX 5100L/LS/XL machines can accommodate workpieces up to 3050mm in length and can machine long tubes such as isolation valves/pipe lines (Oil/Gas) and landing gear axles (Aerospace) that require center bores. Additional (Optional) Long boring bar/Long tool magazine can reduce machining processes/cycle times and improve machining capability.

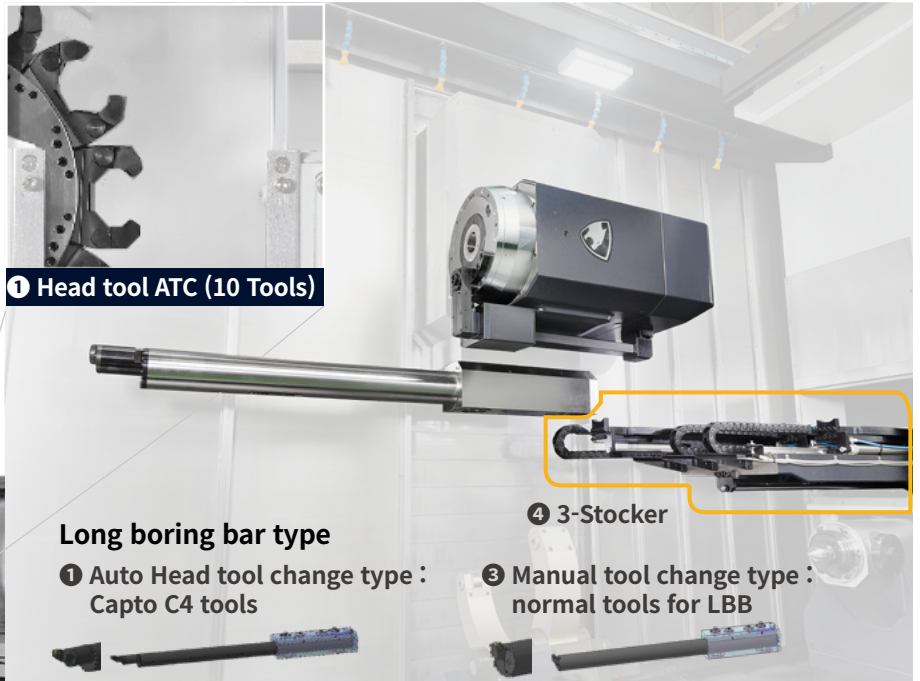
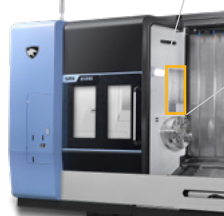

Automatic LBB changer package

{SMX 5100L/LB/XL/XLB OPTION}

Max. LBB size

Ø100 x L1000 mm

(Ø3.9 X 39.4 inch)

Max. weigh

140 kg (308.6 lb)

LBB storage

Max **3** ea

Package name	Composition		
Package A1* (1+2+4)	Auto head tool ATC(C4)	+ LBB(Auto head tool change type)	+ 3-LBB stocker
Package A2 (1+2+3+4)	Auto head tool ATC(C4)	+ Package A1	+ LBB(Manual tool change type) 1EA
Package A3 (1+2+3+3+4)	Auto head tool ATC(C4)	+ Package A1	+ LBB(Manual tool change type) 2EA
Package B1** (3+4)	LBB(Manual tool change type)	+ 3-LBB stocker	
Package B2 (3+3+4)	LBB(Manual tool change type)	+ Package B1	+ LBB(Manual tool change type) 1EA
Package B3 (3+3+3+4)	LBB(Manual tool change type)	+ Package B1	+ LBB(Manual tool change type) 2EA

* Drastically reduce LBB set-up time and optimized package for heavy-duty machining on hard materials.

** Drastically reduce LBB set-up time and high productivity package.

Tool magazine for long tool OPTION

Max. tool size

Ø80 x L1120 mm

(Ø3.1 x L 44.1 inch)

Max. weight

70 kg
(154.3 lb)

Tool storage

4 tools



ERGONOMIC DESIGN

Maximizes user's convenience by employing an ergonomic design concept.

Ease of machine setup through ergonomic design

By laying out the operation panel and tool magazine in a user-friendly way, tooling and workpiece setup become easier for the operator.



1
Wide door ensures the fast and efficient loading/unloading of workpieces using cranes etc



2
Good operator access to the spindle Fast and comfortable work set-up



3
Operation panel with side-to-side movement, swivel action and adjustable height

Swivel angle adjustment : 100°
Height adjustment : 190 mm (7.5 inch)
Longitudinal movement : 2615 mm (103.0 inch)



4
Large front window

Enables the operator to easily monitor the machining area and operations using the front window



5
Front-focused maintenance
Device arrangement such as oil supply and gauges help facilitate daily maintenance activities



CUSTOMIZED USER-FRIENDLY FLEXIBLE OPERATION SOLUTIONS

CUFOS is a PC based control system created by DN Solutions. equipped with intuitive user-friendly functions such as a smart phone screen and easy customization, CUFOS helps to improve operational efficiency and performance for the user.

FEATURES

19 inch TOUCHSCREEN

- Program memory : 40GB
- App-based Interface like smart phone, tablet PC

EASY PROGRAMMING

- Conversational programming
- Sketch cycle : Gear skiving, Gear hobbing, Polygon turning (continuously being added...)
- SSD data server : Program file sharing/managing (CF card/USB/External PC)

EASY SET-UP/OPERATION

- Tool management for SMX
- CPS(collision protection system)
- Manual viewer
- File manager & PDF viewer

EASY MAINTENANCE

- Status monitor
- Alarm guidance
- Maintenance manager
- Easy connection with external S/W (creating additional App.)

CUFOS

for SMX ser.



SKETCH CYCLE

Easy and quick, but powerful programming for complex machining.

Sketch cycle is easy-to-use conversational programming software that make a support to code complex shapes and machining processes such as gear skiving, hobbing and polygon turning.

Advantages

- Easy to use even for beginners with conversational programming by advising workpiece shapes, tool information and machining conditions
- Expensive CAM software is not required
- Reduce coding time by up to 70% while minimizing trial and errors
- Enable to utilize the recent high productivity processing program such as gear skiving



Gear skiving

Gear skiving is carried out in 5 axis machines for more flexible and productive gear machining. The complete component can be finished in one machine, which shorten productiontime and reduce handling and logistics cost.

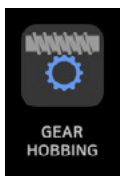
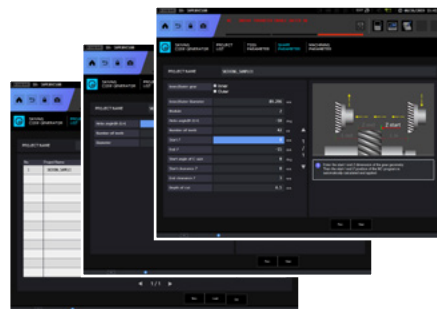

Gear hobbing

Gear hobbing make it easy to proceed gear machining with general turning centers. Gear machining programs can be created by the simple conversational programming so program coding and set-up time can be saved dramatically.

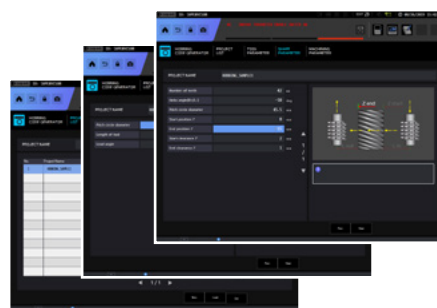

Polygon turning

Polygon turning is a machining process which allows noncircular forms(polygons) to be machine turned without interrupting the rotation of workpieces. It allows rapid production and clean machining of advanced geometries.

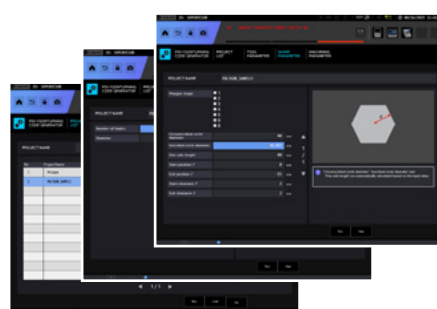

EASY SET-UP | OPERATION

Tool management, collision protection between machine unit/ workpiece/tooling and various user guidance provide higher productivity and user-convenience.

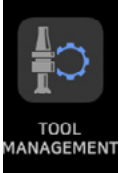

Tool management

DN Solutions EZ work tool management



Includes a summary monitoring screen and gives the operator easy access to DN Solutions's own tool management system which provides comprehensive real time data on each tool, such as remaining tool life and status of tool groups.



CPS (Collision protection system)

A function to prevent real-time collision in manual mode between the tool and equipment / machine elements inside the working area.

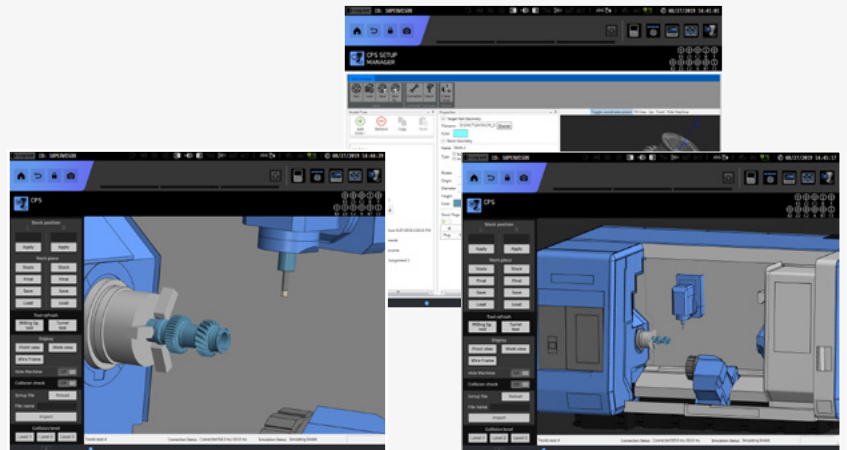
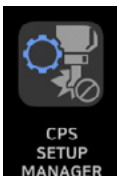

Use the setup manager with the CPS app to build up the machine model, and add tool, workpiece and workholding equipment details.

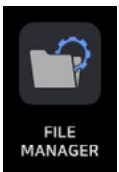

File Manager & PDF viewer

Ability to transfer various type of files including CF cards, USB memory, external PCs and memory inside CUFOS, NC programs between NC memory.

PDF drawings can be directly open on the screen via PDF viewer

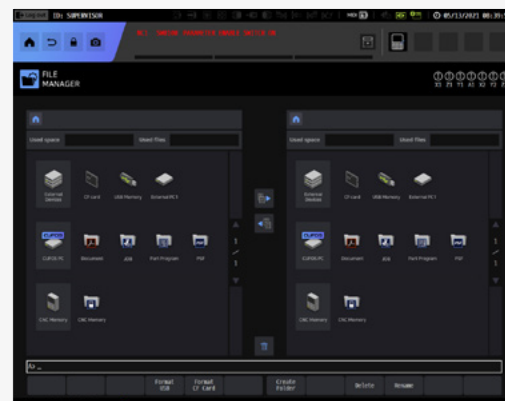

EASY MAINTENANCE

Keeping a machine in best condition through status monitoring, alarm guidance and maintenance manager functions.



Status monitoring

Monitoring various information such as spindle, milling spindle, feed axis, cycle time, program/tool no. on one screen.

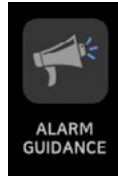
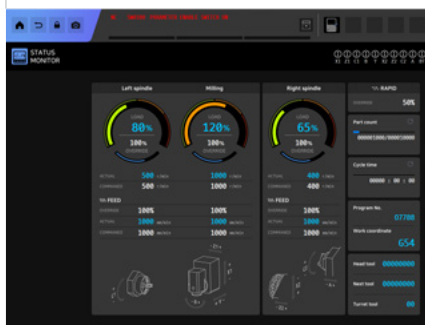

Alarm guidance

Presenting an operator alarm's causes and troubleshooting guides and sending an email when the alarm last for a long time.

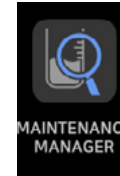
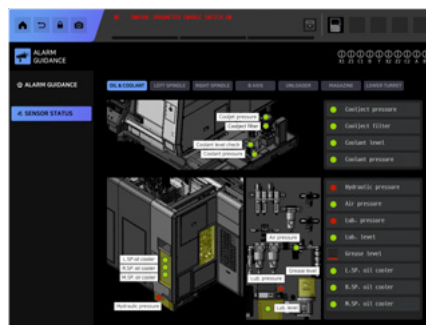

Maintenance manager

Monitors the status of machine and control elements, and confirms the alarm condition and maintenanceschedule for preventative maintenance.



CUFOS: STANDARD | OPTIONAL SPECS

A diverse range of functions and apps are available to meet your needs.

Description	Item	Features	SMX	SMX	SMX	SMX
			5100L(B), 5100XL(B) Fanuc 31i + CUFOS	5100LS(B) Fanuc 31i + CUFOS	5100L(B), XL(B) Fanuc 31i-5 + CUFOS	5100LS(B) Fanuc 31i-5 + CUFOS
Controlled axis	Controlled axes*		7 (X, Z1, C, B, Y, A, {Z2})	8 (X, Z1, C1, B, Y, C2, A, {Z2})	7 (X, Z1, C, B, Y, A, {Z2})	8 (X, Z1, C1, B, Y, C2, A, {Z2})
	Simultaneously controlled axes*		4 axes (Upper X, Z1, C, Y) + 1 axes (Lower {Z2})	4 axes (Upper X, Z1, C1, Y) + 3 axes (Lower {Z2}, C2, A)	5 axes (Upper X, Z1, C, B, Y) + 1 axes (Lower {Z2})	5 axes (Upper X, Z1, C1, B, Y) + 3 axes (Lower {Z2}, C2, A)
Data input/output	Fast data server		○	○	○	○
	Memory card input/output		⊕	⊕	⊕	⊕
	USB memory input/output		●	●	●	●
	SSD Data server	Part program storage size is expanded by 40 GB.	●	●	●	●
Interface function	Embedded ethernet		●	●	●	●
	Fast ethernet		○	○	○	○
	Enhanced embedded ethernet function**		●	●	●	●
Operation	DNC operation	Included in RS232C interface.	●	●	●	●
	DNC operation with memory card		●	●	●	●
	DNC operation with SSD		●	●	●	●
Feed function	AI contour control II	G5.1 Q_, 1000 Blocks	●	●	●	●
Operation guidance function	EZ Guide i(Conversational programming solution)		●	●	●	●
	iHMI with machining cycle		●	●	●	●
	EZ Operation package		●	●	●	●
Setting and display	CNC screen dual display function		●	●	●	●
Network	FANUC MTConnect		⊕	⊕	⊕	⊕
	FANUC OPC UA		⊕	⊕	⊕	⊕
Others	Display unit	15" color LCD	⊕	⊕	⊕	⊕
		19" color LCD with touch panel	⊕	⊕	●	●
	Part program storage size & Number of registerable programs	1280M(512KB)_1000 programs	X	X	X	X
		2560M(1MB)_1000 programs	X	X	X	X
		5120M(2MB)_1000 programs	X	X	X	X
		10240M(4MB)_1000 programs	●	●	●	●
		20480M(8MB)_1000 programs	○	○	○	○
		10240M(4MB)_4000 programs	○	○	○	○
20480M(8MB)_4000 programs	○	○	○	○		

16 * {Z2} axis will be supplied only with servo steady rest option
* With 19" LCD specification, additional confirmation is required

● Standard ○ Optional X N/A ⊕ Available

CONVENIENT OPERATION

SIEMENS SINUMERIK ONE

21.5 inch display + New OP

Two path programs are displayed simultaneously in the large 21.5-inch screen for enhanced user convenience.

- 21.5-inch display
- 6GB user memory
- USB (standard)
- QWERTY keyboard



Convenient conversational functionality

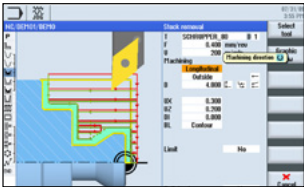

Shopmill / Shopturn

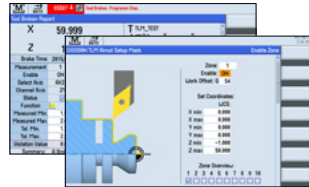

Tool load monitoring

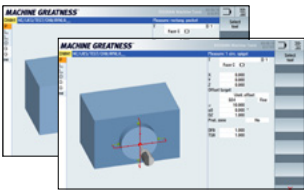

Measuring cycle

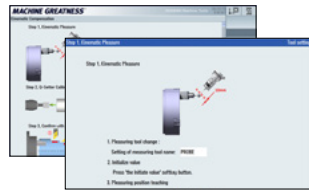

Intelligent kinematic compensation function

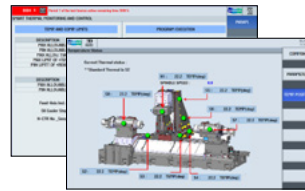

Temperature compensation function



Collision avoidance function

NUMERIC CONTROL SPECIFICATIONS

SIEMENS

Description	Item	Features	SMX 5100L(B), 5100XL(B)	SMX 5100LS(B)	SMX 5100L(B), XL(B)	SMX 5100LS(B)
			SONE	SONE	SONE	SONE
Controlled axis	Controlled axes		7 (X, Z1, C, B, Y, A, {Z2})	8 (X, Z1, C1, B, Y, C2, A, {Z2})	7 (X, Z1, C, B, Y, A, {Z2})	8 (X, Z1, C1, B, Y, C2, A, {Z2})
	Simultaneously controlled axes		4 axes	4 axes	5 axes	5 axes
Data input/output	Memory card input/output		X	X	X	X
	USB memory input/output		●	●	●	●
Interface function	Ethernet (X130)		●	●	●	●
	Execution from External Storage (EES)		○	○	○	○
Operation	On network drive (without EES option, Extcall)		●	●	●	●
	On USB storage medium, e.g. memory stick (without EES option, Extcall)		●	●	●	●
Program input	Workpiece coordinate system G54 - G59, G507 - G599		●	●	●	●
	Advanced surface		●	●	●	●
Feed function	Top surface		○	○	○	○
	Look ahead number of block		1000	1000	1000	1000
Programming & editing function	3D simulation, finished part		●	●	●	●
	Simultaneous recording		●	●	●	●
Operation guidance function	DXF reader for pC integrated in SINUMERIK operate		○	○	○	○
	Shopturn		●	●	●	●
Setting and display	EZ operation package		●	●	●	●
	Operation via a VNC viewer		●	●	●	●
Network	MTCConnect		⊗	⊗	⊗	⊗
	OPCUA		○	○	○	○
Others	Display unit	19" color display without touch screen(SW4.9)	X	X	X	X
		21.5" color display with touch screen(SW4.9)	●	●	●	●
	Part program storage size	CNC user memory 10 MB	●	●	●	●
		CNC user memory 100 MB	○	○	○	○
		CNC user memory 6GB	○	○	○	○
		CNC user memory 40GB (with PCU or IPC)	○	○	○	○
Evaluation of internal drive	CNC user memory without limit (Execution from external storage devices) (EES / Using by USB or network)	○	○	○	○	
	HMI user memory for CNC part program 6GB	●	●	●	●	
	Controllable interpolation axes, extension	○	○	○	○	
	CNC user memory extend	○	○	○	○	
Angle head adapter		○	○	○	○	
Dynamic chuck Dynamic coolant		○	○	○	○	
TOOL ID		○	○	○	○	
PMM		○	○	○	○	

STANDARD | OPTIONAL SPECIFICATIONS

Division	Option	SMX 5100L/XL	SMX 5100LB/XLB	SMX 5100LS	SMX 5100LSB			
Tool shank	CAPTO C8	●	●	●	●			
	HSK-T100	○	○	○	○			
	10.4" operation touch panel	●	●	●	●			
Tool magazine	40 tools	●	●	●	●			
	80 tools	○	○	○	○			
	120 tools	○	○	○	○			
Additional tool magazine	Long tool magazine_4ea	○	○	○	○			
	Automatic LBB changer package A1 or A2 or A3	○	○	X	X			
	Automatic LBB changer package B1 or B2 or B3	○	○	X	X			
Work holding device	Left spindle	Hydraulic chuck 15"	●	X	●	X		
		Hydraulic chuck 18"	○	X	○	X		
		Hydraulic chuck 21"	X	●	X	●		
		Hydraulic chuck 24"	X	○	X	○		
		Hydraulic chuck 15"	X	X	●	X		
	Right spindle	Hydraulic chuck 18"	X	X	○	X		
		Hydraulic chuck 21"	X	X	X	●		
		Hydraulic chuck 24"	X	X	X	○		
		Dual pressure chucking (High pressure/High pressure)	○	○	○	○		
	Chuck clamp & unclamp		●	●	●	●		
	Work holding device	Single type	No parking function	SLU5.1 (Ø85 ~ Ø350)	○	○	○	○
				K5.1 (Ø100 ~ Ø410)	○	○	○	○
				K6.0 (Ø135 ~ Ø460)	○	○	○	○
			Parking function (for 15" Chuck)	K5.1 (Ø100 ~ Ø410)	○	○	○	○
				K6.0 (Ø135 ~ Ø460)	○	○	○	○
K6.1 (Ø215 ~ Ø510)				○	○	○	○	
Parking function (for 18" Chuck)		K6.1 (Ø215 ~ Ø510)	○	○	○	○		
		Double type	No parking function	SLU5.1 (Ø85 ~ Ø350)	○	○	○	○
				K5.1 (Ø100 ~ Ø410)	○	○	○	○
K6.0 (Ø135 ~ Ø460)				○	○	○	○	
Parking function (for 15" Chuck)			K5.1 (Ø100 ~ Ø410)	○	○	○	○	
			K6.0 (Ø135 ~ Ø460)	○	○	○	○	
			K6.1 (Ø215 ~ Ø510)	○	○	○	○	
Servo driven steady rest (Z-movement)		Twin type	No parking function	SLU5.1 (Ø85 ~ Ø350)	○	○	○	○
				K5.1 (Ø100 ~ Ø410)	○	○	○	○
	STA-5.1 (Ø85 ~ Ø350)			○	○	○	○	
	Single type	No parking function	AX8E, AX8I (Ø85~Ø360)	○	○	○	○	
			AX8.5E, AX8.5I (Ø100~Ø430)	○	○	○	○	
			AX8.7E, AE8.7I (Ø140~Ø470)	○	○	○	○	
		Parking function (for 15" Chuck)	AX9I (Ø100~Ø510)	○	○	○	○	
			AX8.5E, AX8.5I (Ø100~Ø430)	○	○	○	○	
			AX8.7E, AE8.7I (Ø140~Ø470)	○	○	○	○	
Parking function (for 18" Chuck)	AX9I (Ø100~Ø510)	○	○	○	○			
	Double type	No parking function	AX8E, AX8I (Ø85~Ø360)	○	○	○	○	
			AX8.5E, AX8.5I (Ø100~Ø430)	○	○	○	○	
AX8.7E, AE8.7I (Ø140~Ø470)			○	○	○	○		
Parking function (for 18" Chuck)		AX9I (Ø100~Ø510)	○	○	○	○		
		Twin type	No parking function	AX8E, AX8I (Ø85~Ø360)	○	○	○	○
				Coolant	T-T-C (Milling spindle)	Pressure 1.0MPa (145 psi)/ Element filter	●	●
Pressure 3.0MPa (435 psi)/ Cyclone filter	○					○	○	○
Pressure 7.0MPa (1015 psi) / Cyclone filter	○	○	○			○		
Chip disposal	Oil skimmer	○	○	○	○			
	Coolant pressure switch (Standard for milling spindle)	●	●	●	●			
	Coolant level switch : Sensing level - Low	○	○	○	○			
	Chip conveyor (Right disposal)	Hinged belt type	○	○	○	○		
		Magnetic scraper type	○	○	○	○		
		Drum filter with hinge scraper type	○	○	○	○		
	Chip bucket	○	○	○	○			
	Air blower (for Left or Right spindle chuck)	●	●	●	●			
	Chuck coolant (for Left or Right spindle chuck)	○	○	○	○			
	Through spindle air (for Left or Right spindle)	○	○	○	○			
	Through spindle coolant (Left or Right)	○	○	○	○			
	Through spindle air & air blower (for milling spindle)	○	○	○	○			
	Shower coolant(1.1kW, 165 liter/min)	○	○	○	○			
	Coolant gun	○	○	○	○			
	Air gun	○	○	○	○			
Mist collector	○	○	○	○				
High accuracy	Thermal compensation	●	●	●	●			
	Ball screw core cooling (X/Y/Z-axis)	○	○	○	○			
	Oil cooling flow detector(for spindle, ball screw)	○	○	○	○			
	Water soluble Coolant Chiller**	○	○	○	○			
	Linear scale (X-axis)	○	○	○	○			
Measurement	Linear scale (Y-axis)	○	○	○	○			
	Linear scale (Z-axis)	○	○	○	○			
	Auto tool setter (Linear, Touch probe)	○	○	○	○			
Automation	Auto tool setter (NC4. Laser)	○	○	○	○			
	Auto workpiece measurement (RMP60)	○	○	○	○			
	Intelligent kinematic compensation for multi-tasking (Software customized by DN Solutions)	●	●	●	●			
Others	Intelligent kinematic compensation for multi-tasking (Datum Ball)	○	○	○	○			
	Robot interface	○	○	○	○			
	Automatic front door (with safety device)	○	○	○	○			
Standard accessories	U-axis_DANDREA TA-C160	○	○	○	○			
	Air limit sensing	○	○	○	○			
	Auto power off	○	○	○	○			
	Portable MPG	○	○	○	○			
	Rotary type window wiper	○	○	○	○			
Standard accessories	Foundation bolt for anchoring	●	●	●	●			
	Signal tower	●	●	●	●			
	DN Solutions tool monitoring system	●	●	●	●			
	Foot switch_sigle	●	●	●	●			

* Please contact your DN Solutions representative for detailed machine information.

* When using a semi-synthetic type or synthetic type, contact our sales representative or service center in advance.

** Technical consultation is mandatory for the chilling of non-water soluble coolant.

● Standard ○ Optional X N/A

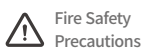

There is a high risk of fire when using non-water-soluble cutting fluids, processing flammable materials, neglecting the controlled and careful use of coolants and modifying the machine without the consent of the manufacturer. Always check the SAFETY GUIDELINES carefully before using the machine.

PERIPHERAL EQUIPMENT

Tool setter (Automatic) OPTION

Auto linear motion type tool setter for tool measurement and tool wear detection.



Linear scales OPTION

Linear scales are ideal for high accuracy simultaneous 5-axis machining, high feed precision and machining over long periods of time.



Coolant chiller (Recommendation) OPTION

Coolant chiller is highly recommended to prevent temperature rise and minimize thermal deformation, when using a water-insoluble coolant or high-pressure coolant system of which the power is over 1.5 kw.

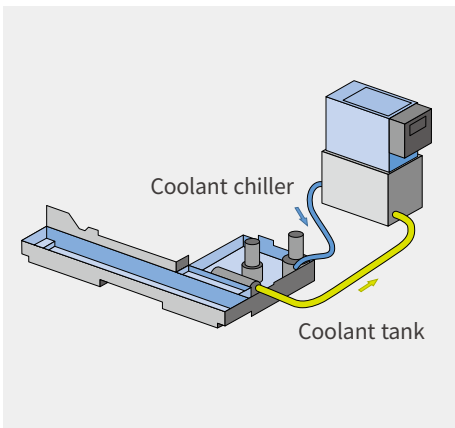

Servo driven steady rest OPTION

Steady rests support long workpieces during the machining process. Linear positioning of the steady rest is achieved by the servo motor and ball screw and can be positioned in cycle.

Steady rest parking function

When the steady rest is not being used it can be parked under the left chuck.



Size		Type			
		Single	Double	Twin	Parking function (Single)
SLU5.1 / STA5.1	Ø85-Ø350	○	○	○	X
K5.1	Ø100-Ø410	○	○	○	○ (w/ 15"Chuck)
K6.0	Ø135-Ø460	○	○	X	○ (w/ 15"Chuck)
K6.1	Ø215-Ø510	○	○	X	○ (w/ 15",18" Chuck)
RX6.1*	Ø250-Ø685	○	X	X	○ (w/ 15",18",21"Chuck)
AX8E, AX8I	Ø85-Ø360	○	○	○	X
AX8.5E, AX8.5I	Ø100-Ø430	○	○	X	○(w/ 15"Chuck)
AX8.7E, AE8.7I	Ø140-Ø470	○	○	X	○(w/ 15"Chuck)
AX9I	Ø100-Ø510	○	○	X	○(w/ 15", 18"Chuck)



SINGLE

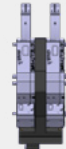

DOUBLE

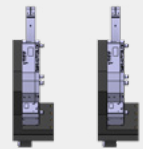

TWIN

* RX 6.1 requires discussion with DN Solutions.

Chip conveyor (Right side exit) OPTION

The conveyor provides a superior chip removal system and has a stable structure for easy maintenance and reduced leakage. By selecting the correct type of conveyor, the efficiency of the machine is increased.

Name	Hinge belt	Magnetic scraper	Drum filter + Hinge scraper (Double type)
Application	For steel	For castings	For steel, castings, nonferrous metal
Features	<ul style="list-style-type: none"> General Appropriate for a heavy material chip of more than 30 mm in length 	<ul style="list-style-type: none"> Easy maintenance Eject the chip by scraping and raising the chip with the scraper 	<ul style="list-style-type: none"> For steel, castings, nonferrous metal Appropriate for both a long and a short chip - Filtering coolant
Shape			

U-axis OPTION

D'Andrea TA-C170(Ø460mm), ID/OD/taper turning in random angles and various surface shapes is possible, while maintaining higher productivity and precise roundness.



< U-axis turning sample >

POWER | TORQUE

SMX 5100 series

**Left spindle (SMX 5100L/LS/XL)
Right spindle (SMX 5100LS)**

Max. spindle power

37 / 30 kW (49.6 / 40.2 Hp)

Max. Spindle torque

1634 N·m (1205.9 ft-lbs)

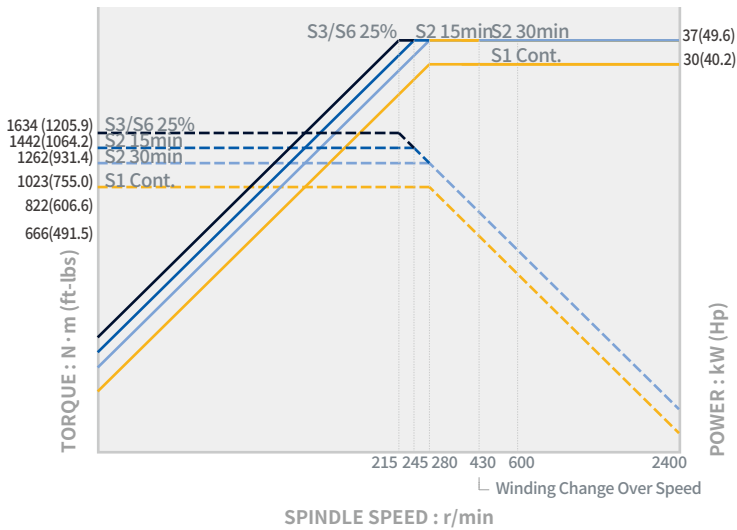

Milling spindle

Max. spindle power

29.5 / 21.8 kW (39.6 / 29.2 Hp)

Max. Spindle torque

302 N·m (222.9 ft-lbs)

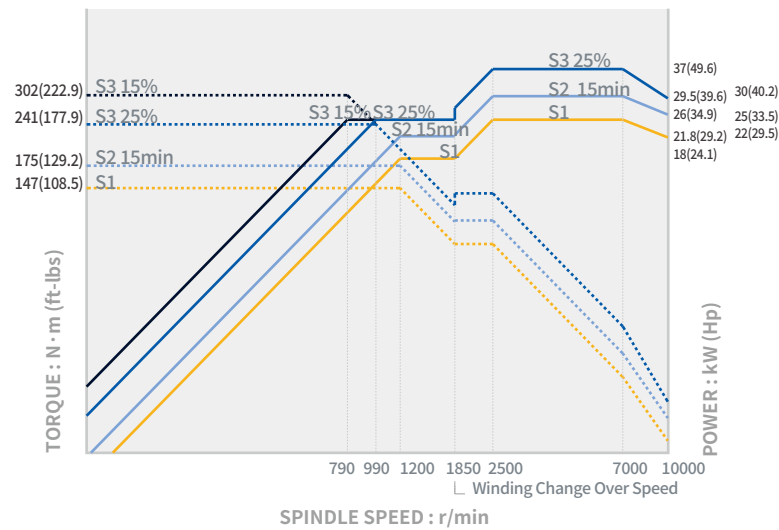

**Left spindle (SMX 5100LB/LSB/XLB)
Right spindle (SMX 5100LSB)**

Max. spindle power

37/ 22 kW (49.6 / 29.5 Hp)

Max. Spindle torque

1634 N·m (1205.9 ft-lbs)

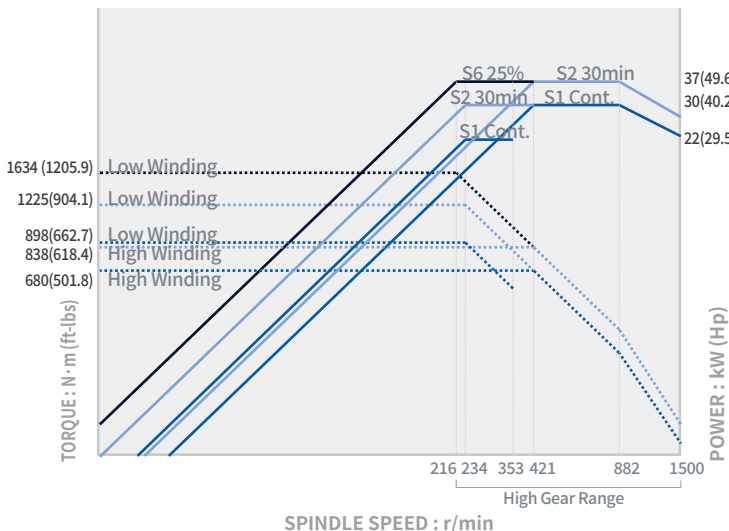

**Left spindle (SMX 5100LB/LSB/XLB)
Right spindle (SMX 5100LSB)**

Max. spindle power

37 / 22 kW (49.6 / 29.5 Hp)

Max. Spindle torque

4200 N·m (3099.6 ft-lbs)

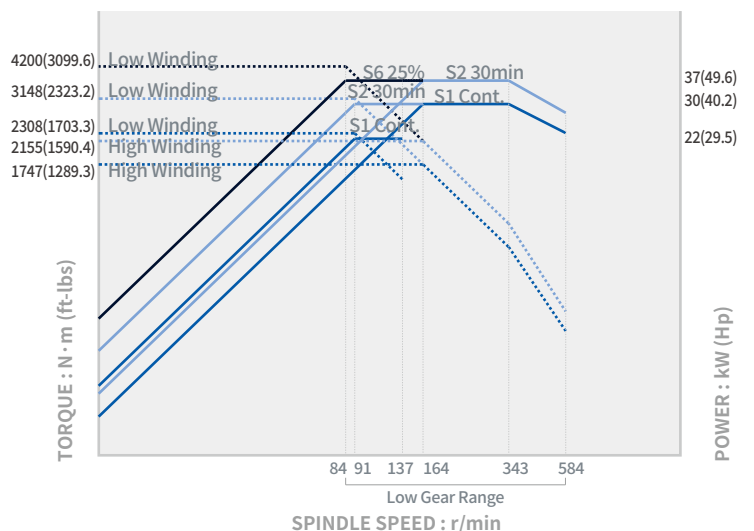

EXTERNAL DIMENSIONS

SMX 5100L / LS / LB / LSB

Unit : mm (inch)

TOP

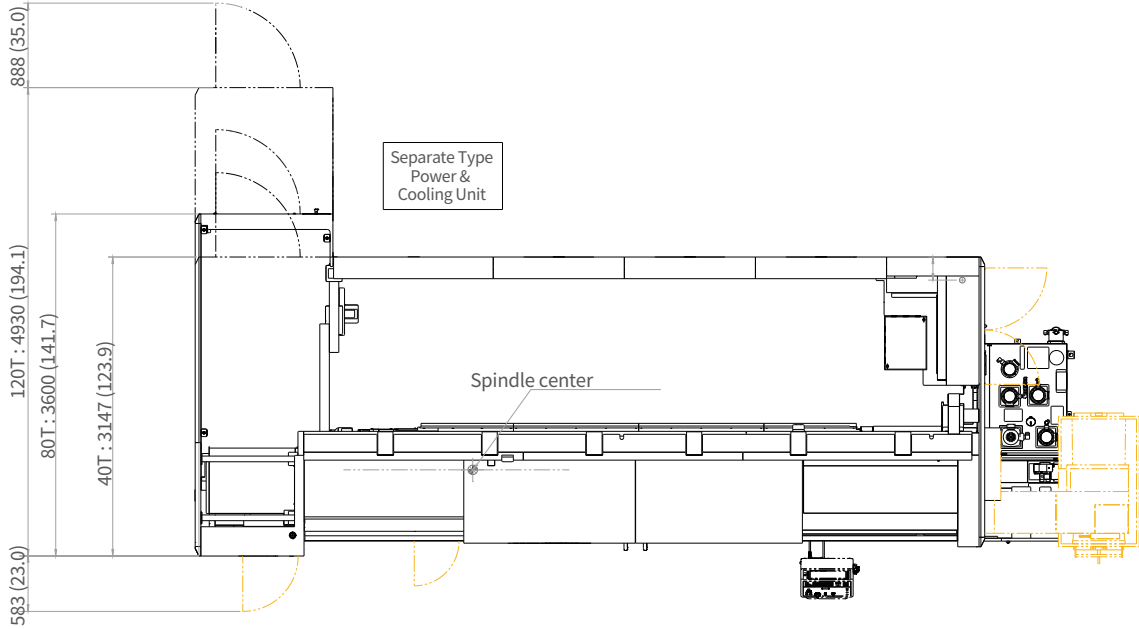

FRONT

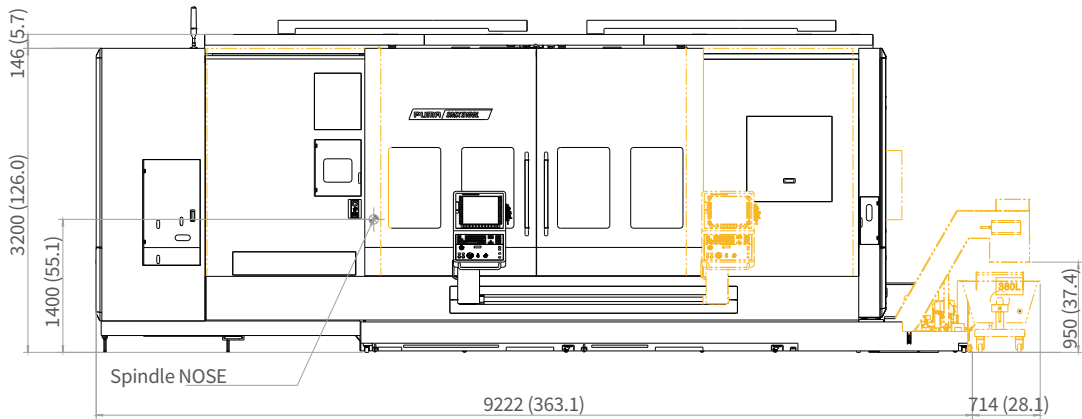

*Some peripheral equipment can be placed in other areas.

EXTERNAL DIMENSIONS

SMX 5100XL/XLB

Unit : mm (inch)

TOP

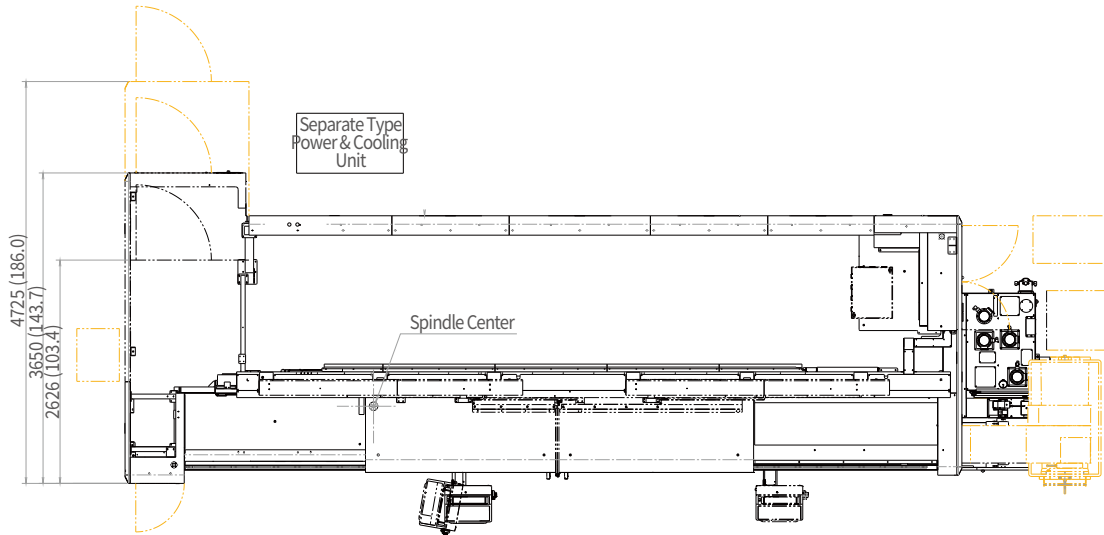

FRONT

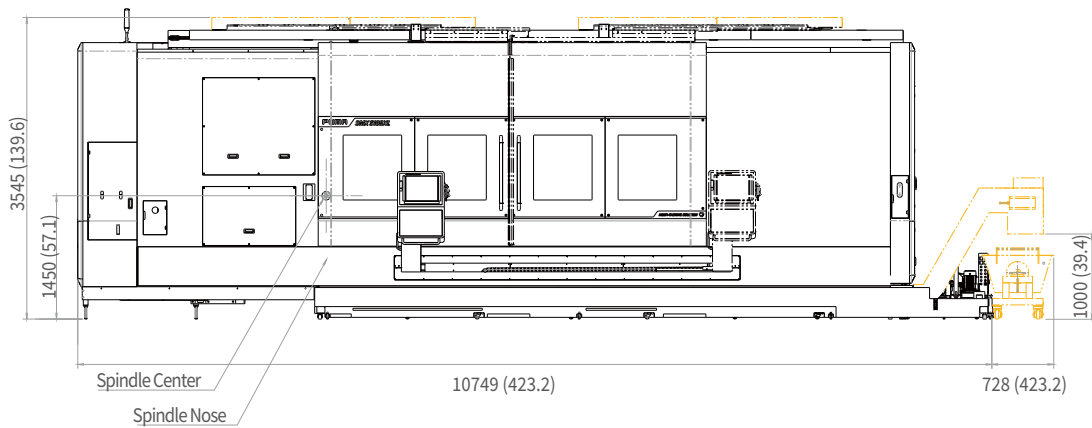

WORKING RANGE

SMX 5100L/LB

Unit : mm (inch)

ENTIRE RANGE

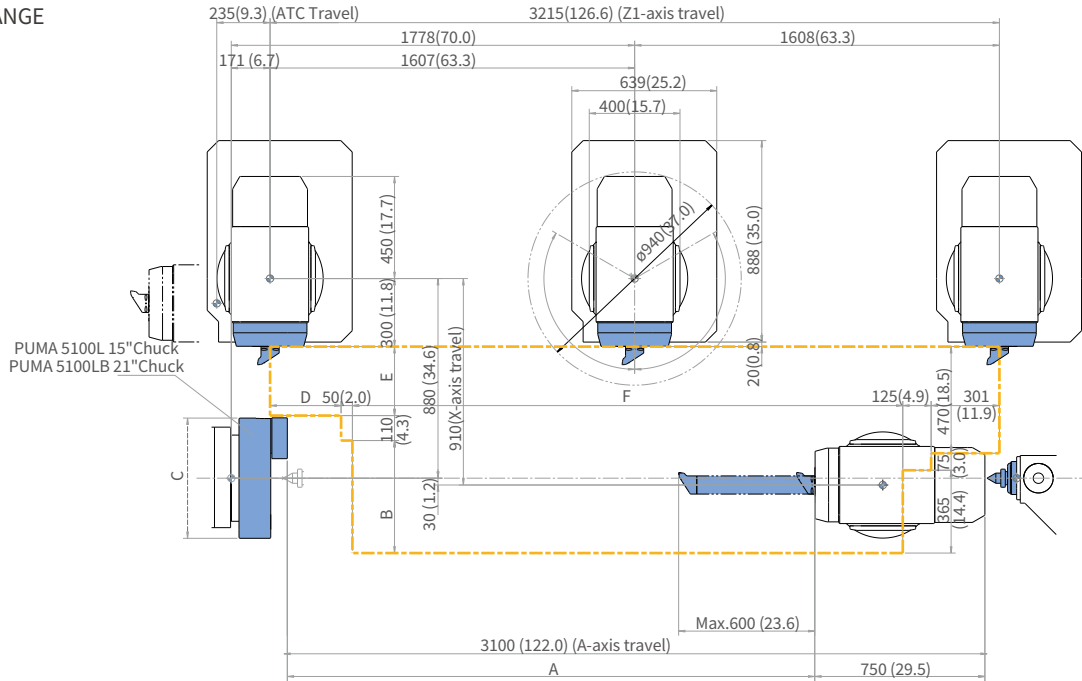

Model	A	B	C	D	E	F
SMX 5100L	2352 (92.6)	424 (16.7)	381 (15.0)	285 (11.2)	376 (14.8)	2454 (96.6)
SMX 5100LB	2325 (91.5)	496 (19.5)	530 (20.9)	313 (12.3)	304 (12.0)	426 (95.5)

Y-AXIS WORKING RANGE

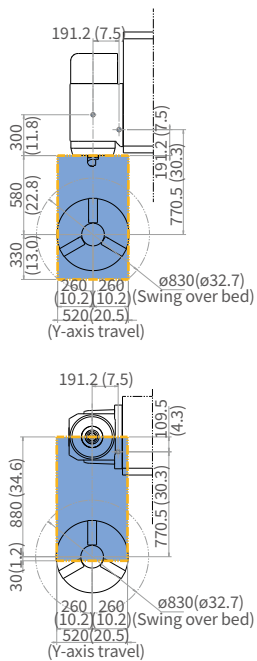

B-AXIS ROTATING RANGE

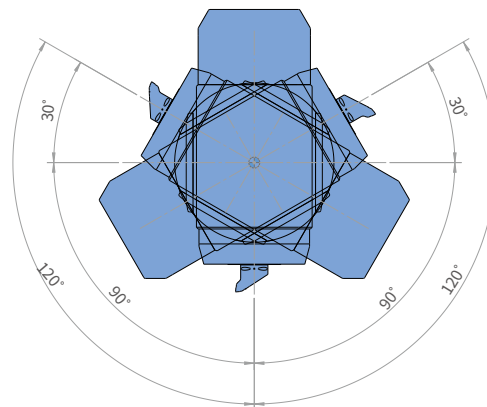

WORKING RANGE

SMX 5100LS/LSB

Unit : mm (inch)

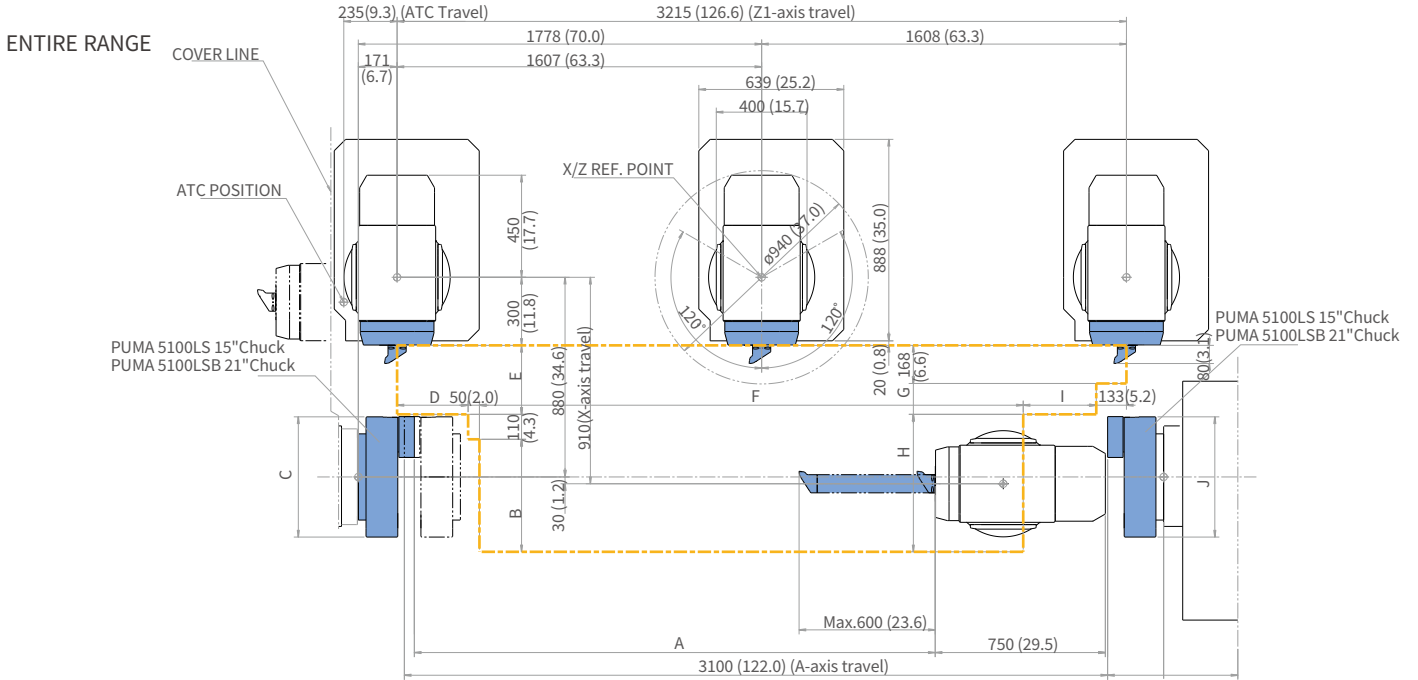

Model	A	B	C	D	E	F	G	H	I	J
SMX 5100LS	2352 (92.6)	424 (16.7)	381 (15.0)	285 (11.2)	376 (14.8)	2453 (96.6)	208 (8.2)	534 (21.0)	294 (11.6)	381 (15.0)
SMX 5100LSB	2296 (90.4)	496 (19.5)	530 (20.9)	313 (12.3)	304 (12.0)	2397 (94.4)	136 (5.4)	606 (23.9)	322 (12.7)	530 (20.9)

Y-AXIS WORKING RANGE

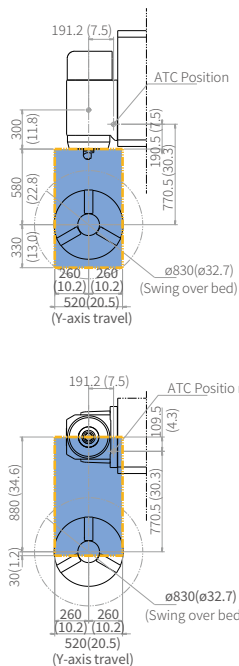

B-AXIS ROTATING RANGE

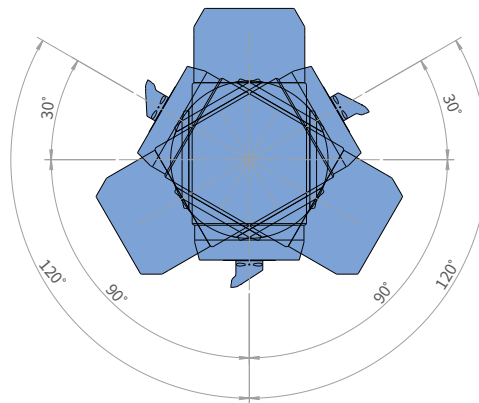

MACHINE SPECIFICATIONS

SMX 5100 series

Item		Unit	SMX 5100L	SMX 5100LB	SMX 5100LS	SMX 5100LSB	SMX 5100XL	SMX 5100XLB	
Capacity	Swing over bed	mm (inch)	830(32.7)						
	Recom. turning diameter	mm (inch)	530 (20.8)						
	Max. turning diameter	mm (inch)	830(32.7)						
	Max. turning length	mm (inch)	3050(120.1)						
	Chuck size	Left spindle	inch	15	21	15	21	15	21
		Right spindle	inch	-	-	15	21	-	-
	Max. material weight	Flange (include chuck)	kg (lb)	840(1851.9)	1700(3747.8)	840(1851.9)	1700(3747.8)	840(1851.9)	1700(3747.8)
Shaft (include chuck)		kg (lb)	1400(3086.4)	2600(5731.9)	-	-	1400(3086.4)	2600(5731.9)	
Bar working diameter	mm (inch)	102(224.9)	165.5(364.9)	102(224.9)	165.5(364.9)	102(224.9)	165.5(364.9)		
Travels	Travel distance	X-axis	910(35.8) (-30/+880) (-1.2/+34.6)						
		Y-axis	520(±260) (20.5(±10.2))						
		Z-axis	3215(126.6)						
		A-axis	3100(122.0)						
		B-axis	240						
		C1-axis	360						
	C2-axis	360							
Rapid traverse rate	X-axis	m/min (ipm)	40(1574.8)						
	Y-axis	m/min (ipm)	40(1574.8)						
	Z-axis	m/min (ipm)	40(1574.8)						
	A-axis	m/min (ipm)	14(551.2)						
	B-axis	r/min	30						
	C1-axis	r/min	100	20	100	20	100	20	
C2-axis	r/min	-	-	100	20	-	-		
Left spindle	Max. spindle speed	r/min	2400	1500	2400	1500	2400	1500	
	Spindle motor power	kW (Hp)	37/30 (49.6/40.2) (30min/S1 Cont.)						
	Spindle nose	ASA	A2-11	A2-15	A2-11	A2-15	A2-11	A2-15	
	Spindle bearing diameter (Front)	mm (inch)	180(7.1)	240(9.4)	180(7.1)	240(9.4)	180(7.1)	240(9.4)	
	Spindle through hole	mm (inch)	120(4.7)	185(7.3)	120(4.7)	185(7.3)	120(4.7)	185(7.3)	
	Min. spindle indexing angle (C1-axis)	deg	0.0001						
	Max. spindle speed	r/min	-	-	2400	1500	-	-	
Right spindle	Spindle motor power	kW (Hp)	-	-	37/30 (49.6/40.2) (30min/S1 Cont.)	-	-		
	Spindle nose	ASA	-	-	A2-11	A2-15	-		
	Spindle bearing diameter (Front)	mm (inch)	-	-	180(7.1)	240(9.4)	-		
	Spindle through hole	mm (inch)	-	-	120(4.7)	185(7.3)	-		
	Min. spindle indexing angle (C2-axis)	deg	-	-	0.0001				
	Max. spindle speed	r/min	10000						
Milling spindle	Milling spindle motor power	kW	37/30/25 (49.6/40.2/33.5) (2.5min/30min/Cont.)						
	Min. spindle indexing angle (B-axis)	deg.	0.0001						
	No. of tool stations	ea	40 {80,120}						
Automatic tool changer	Tool shank		CAPTO C8						
	Max. tool	Diameter continuous	135(5.3)						
		Diameter without adjacent tools	260(10.2)						
	Max. tool length	mm (inch)	600(23.6)						
	Max. tool weight	kg (lb)	30(66.1)						
	Max. tool moment	N·m (ft·lbs)	29.4(21.7)						
	Tool change time (T-T)	Tool-to-Tool	sec	2.4 (Fanuc) / 2.13(SIEMENS)				2.6 (Fanuc) / 2.13(SIEMENS)	
Chip-to-Chip		sec	13.2 (Fanuc) / 19.67 (SIEMENS)				18.2 (Fanuc) / 19.67 (SIEMENS)		
Long tool magazine	Max. tool storage capacity	ea	4						
	Max. tool size	mm (inch)	Ø80 x 1120 (Ø3.1 x 44.1)						
	Max. tool weight	kg (lb)	70(154.3)						
Automatic LBB(Long boring bar) changer	Max. tool storage capacity	ea	3	-	-	-	3		
	Max. tool size	mm	Ø100 x 1000 (Ø3.9 x 39.4)				Ø100 x 1000 (Ø3.9 x 39.4)		
	Max. tool weight0 (Boring bar holder)	kg (lb)	140(308.6)				140(308.6)		
	Auto Head tool change (for Long Boring Bar Type)	Max. tool storage capacity	ea	10				10	
		Head tool type		CAPTO C4				CAPTO C4	
		Max. tool size	mm (inch)	75(3.0)				75(3.0)	
Max. tool weight		kg	1				1		
Tail Stock	Quill bore taper	MT	#5				#6		
	Tail stock travel	mm (inch)	3100(122.0)				4100(161.4)		
Powersource	Electric power supply (rated capacity)	kVA	95.73	98.63	118.50	121.68	96.01	98.92	
Machine dimensions	Height	mm (inch)	3346(131.7)	3346(131.7)	3346(131.7)	3346(131.7)	3398(133.8)	3398(133.8)	
	Length	mm (inch)	9222(363.1)	9222(363.1)	9522(374.9)	9522(374.9)	10749(423.2)	10749(423.2)	
	Width	mm (inch)	3597(141.6)	3597(141.6)	3597(141.6)	3597(141.6)	3597(141.6)	3597(141.6)	
	Weight	kg (lb)	31000(68342.3)	33000(72751.5)	32200(70987.8)	35900(79144.8)	37000(81569.8)	39000(85979.0)	
Control	NC system	CUFOS(Fanuc base)							

*{ } : Optimal

RESPONDING TO CUSTOMERS **ANYTIME, ANYWHERE**

DN SOLUTIONS GLOBAL NETWORK

66 COUNTRIES | **140** + SALES NETWORKS | **3** FACTORIES | **6** REGIONAL HQS



CUSTOMER SUPPORT AND SERVICES

WE'RE THERE FOR YOU WHENEVER YOU NEED US.

We help our customers operate at maximum efficiency by providing them with a range of tried, tested and trusted services - from pre-sales consultancy to post-sales support.



FIELD SERVICES

- On-site service
- Machine installation and testing
- Scheduled preventive maintenance
- Machine repair service



PARTS SUPPLY

- Supplying a wide range of original DN Solutions spare parts
- Parts repair service



TRAINING

- Programming, machine setup and operation
- Electrical and mechanical maintenance
- Applications engineering



TECHNICAL SUPPORT

- Supports machining methods and technology
- Responds to technical queries
- Provides technical consultancy

**Head Office**

19F, 10, Tongil-ro, Jung-gu, Seoul,
Republic of Korea, 04527

Tel: +82-2-6972-0370
Fax: +82-2-6972-0400

DN Solutions America

360 E State PKWY,
Schaumburg, IL. 60173,
United states

Tel: +1-315-265-7500

DN Solutions Europe

Emdener Strasse 24, D-41540
Dormagen, Germany

Tel: +49-2133-5067-100
Fax: +49-2133-5067-111

DN Solutions India

No.82, Jakkur Village
Yelahanka Hobli,
Bangalore-560064

Tel: +91-80-2205-6900
E-mail: india@dncompany.com

DN Solutions China

Room 101,201,301,
Building 39 Xinzhuan Highway
No.258 Songjiang District
China Shanghai (201612)

Tel: +86 21-5445-1155
Fax: +86 21-6405-1472

DN Solutions Vietnam

M.O.R.E building 2F, 40A-40B Ut
Tich Street, 04 Ward 04,
District Tan Binh District,
Ho Chi Minh City, Vietnam

Tel: +84 28-7304-0163

DN Solutions Mexico

Avenida Parque Bicentenario
#100 Nave M65L3-6,
Fraccionamiento San Isidro
Business Park,
Santa Rosa Jauregui,
Querétaro, México

E-mail: efrain.figueroa@dncompany.com

Sales inquiry

sales@dncompany.com